



Minimum Width : 1,000 mm

Maximum Width : 1,100 mm

Tailgate Frame Height : 980 mm

Internal Height : 1,080 mm

New 2012+ Isuzu D-Max.MK.6 (RT50) Dbl-Cab



Minimum Width : 970 mm

Height : 470 mm

Maximum Width : 1,010 mm



Minimum Width : 1,060 mm

Maximum Width : 1,210 mm

Tailgate Frame Height : 950 mm

Internal Height : 1,030 mm



Minimum Width : 950 mm

Height : 470 mm

Maximum Width : 1,060 mm



Minimum Width : 950 mm

Maximum Width : 1,150 mm

Tailgate Frame Height : 940 mm

Internal Height : 1,000 mm

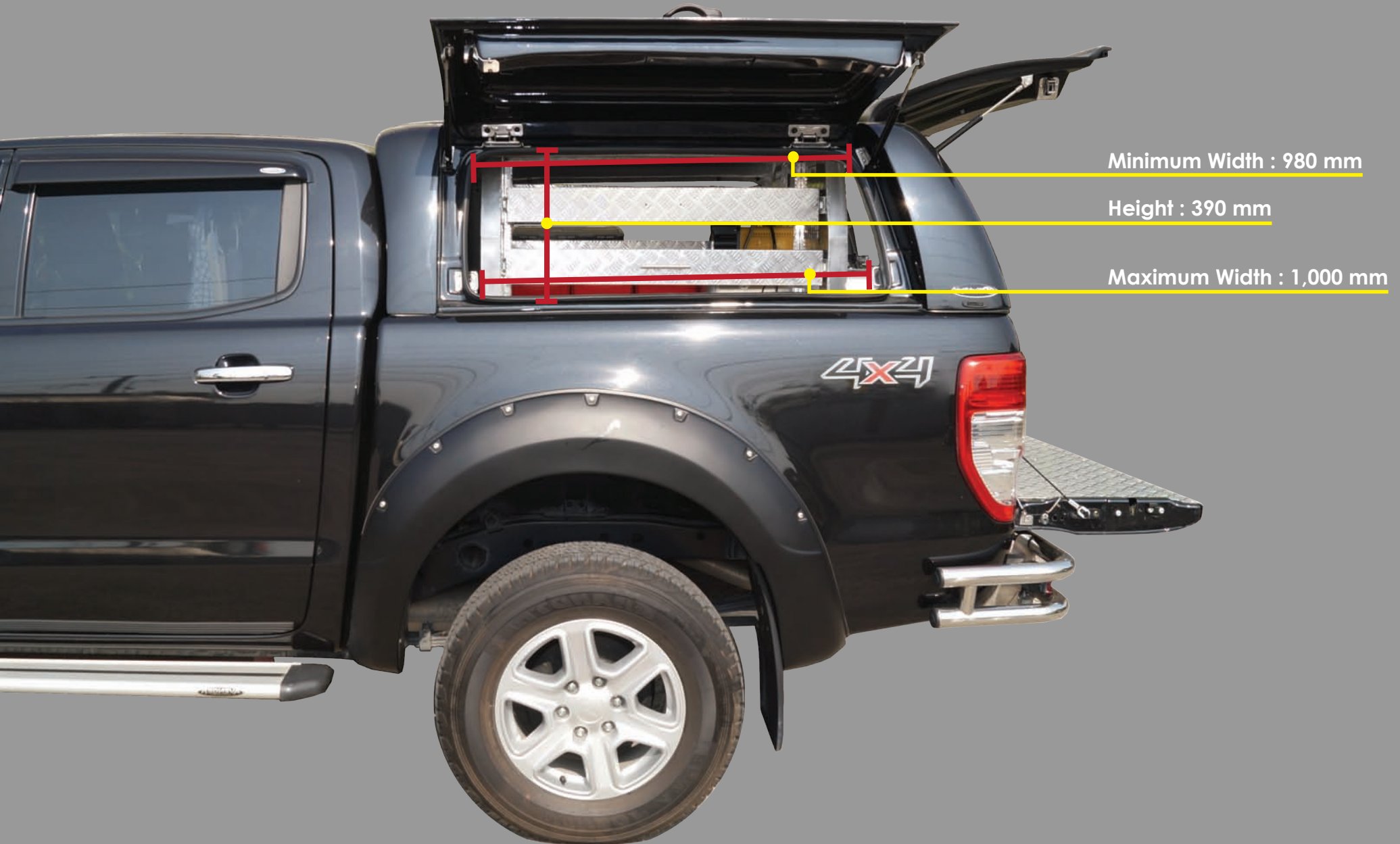

Minimum Width : 980 mm

Height : 390 mm

Maximum Width : 1,000 mm



Minimum Width : 950 mm

Maximum Width : 1,100 mm

Tailgate Frame Height : 900 mm

Internal Height : 980 mm

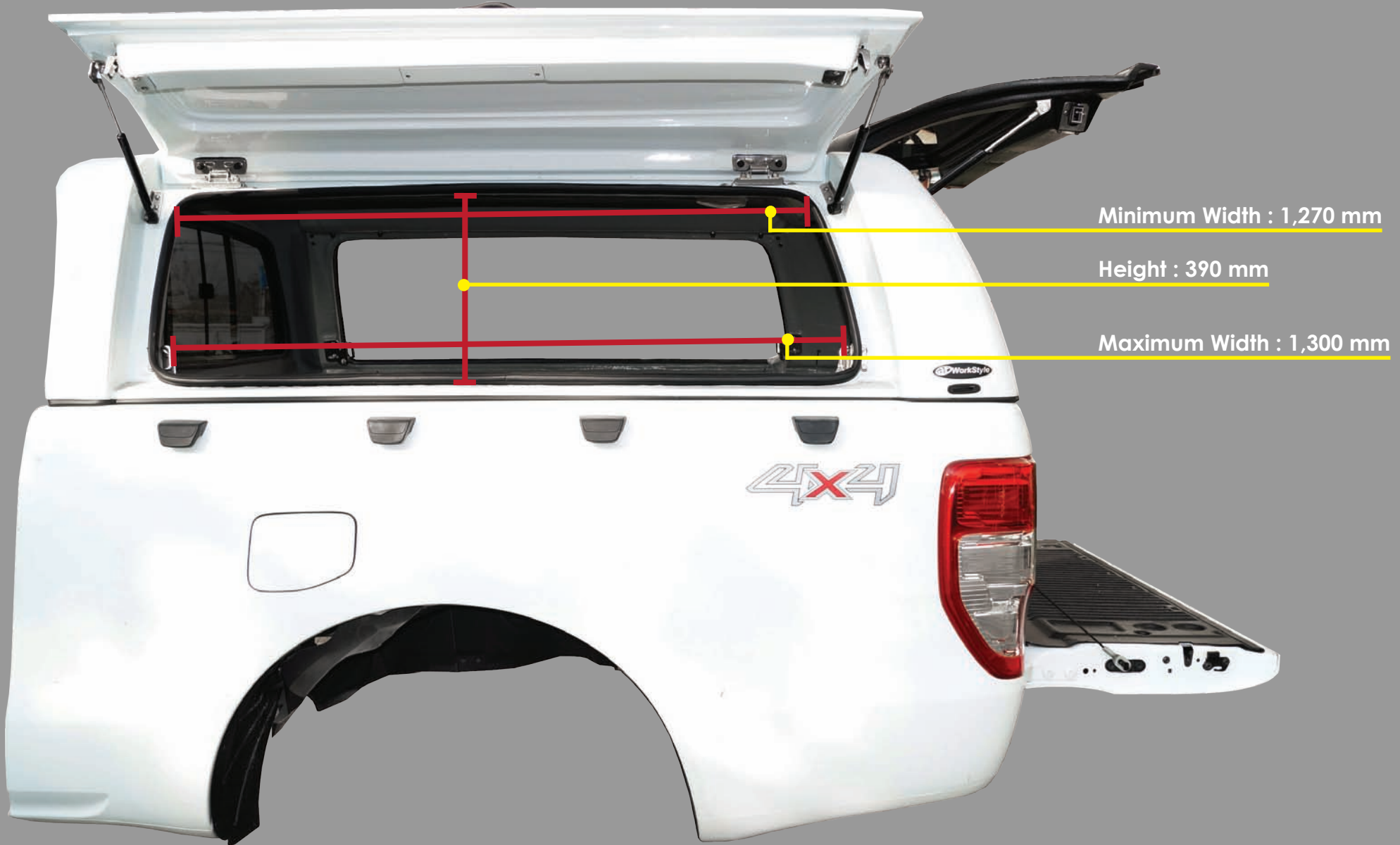

New 2012+ Ford Ranger.MK.5 (PX Ranger/T6) Extra-Cab

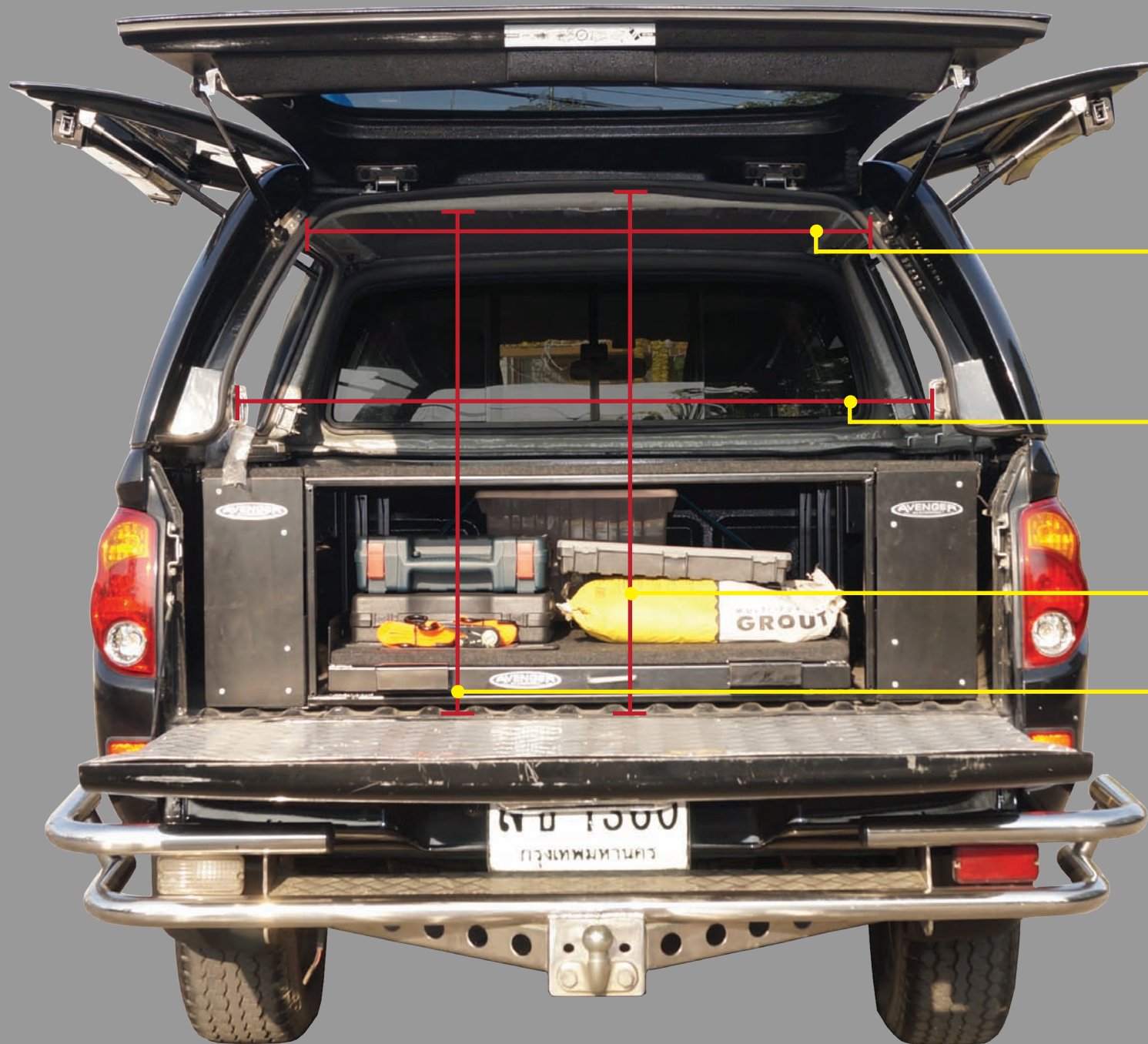

Minimum Width : 980 mm

Maximum Width : 1,160 mm

Tailgate Frame Height : 860 mm

Internal Height : 960 mm

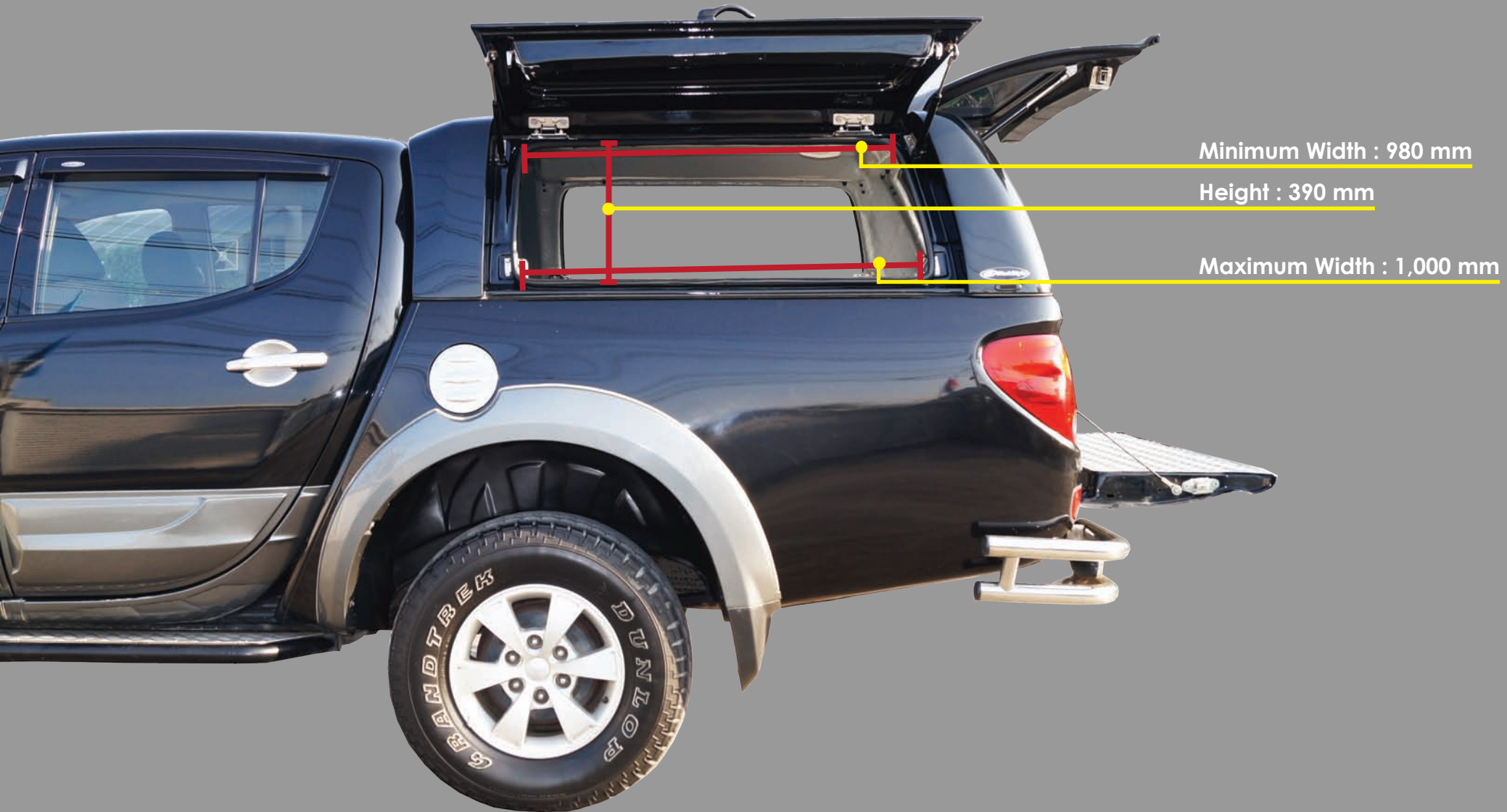

Minimum Width : 980 mm

Height : 390 mm

Maximum Width : 1,000 mm

Old Mitsubishi L200.MK.6 (MN Triton) Long bed Dbl-Cab

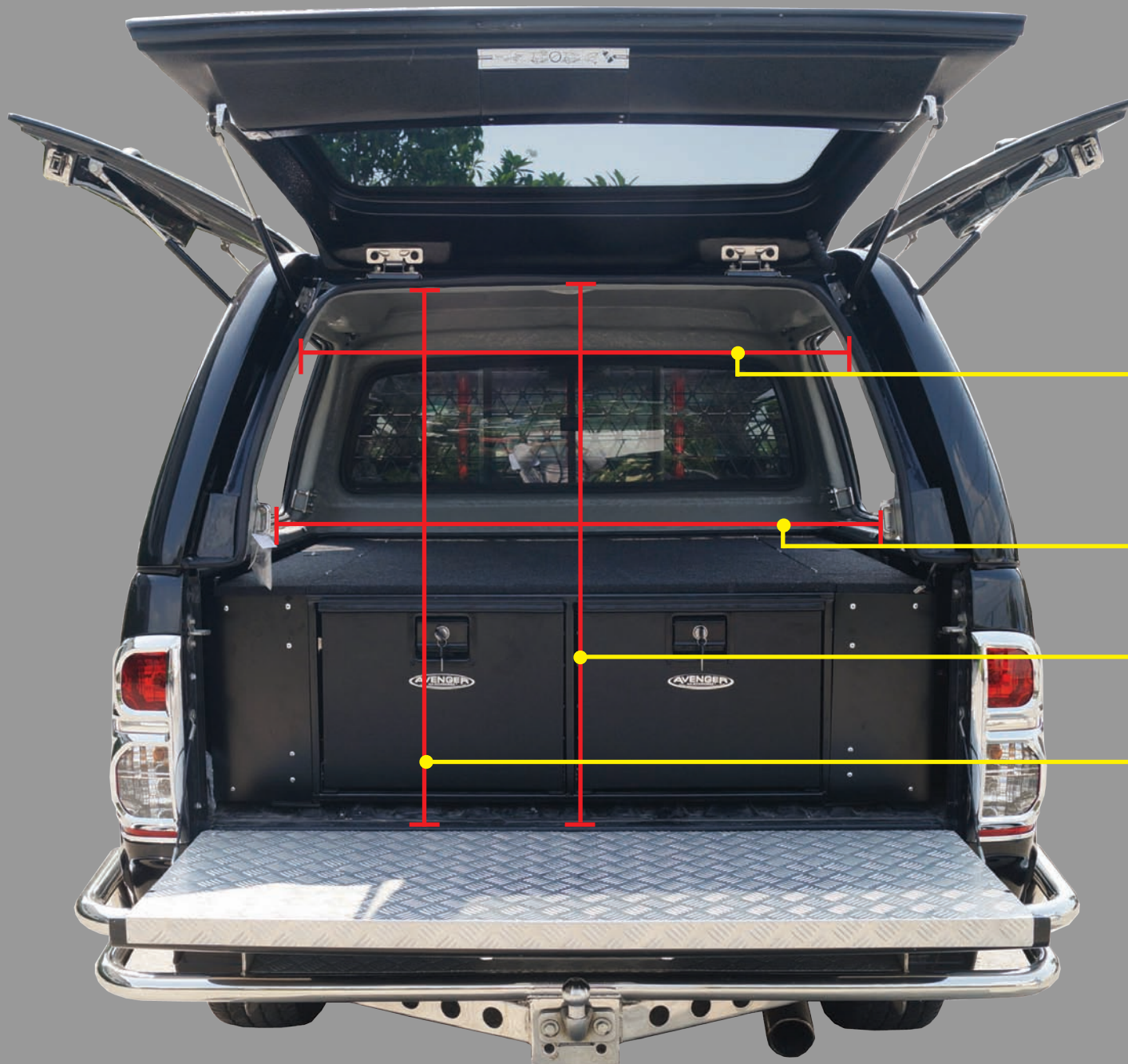

Minimum Width : 950 mm

Maximum Width : 1,110 mm

Tailgate Frame Height : 995 mm

Internal Height : 1,065 mm

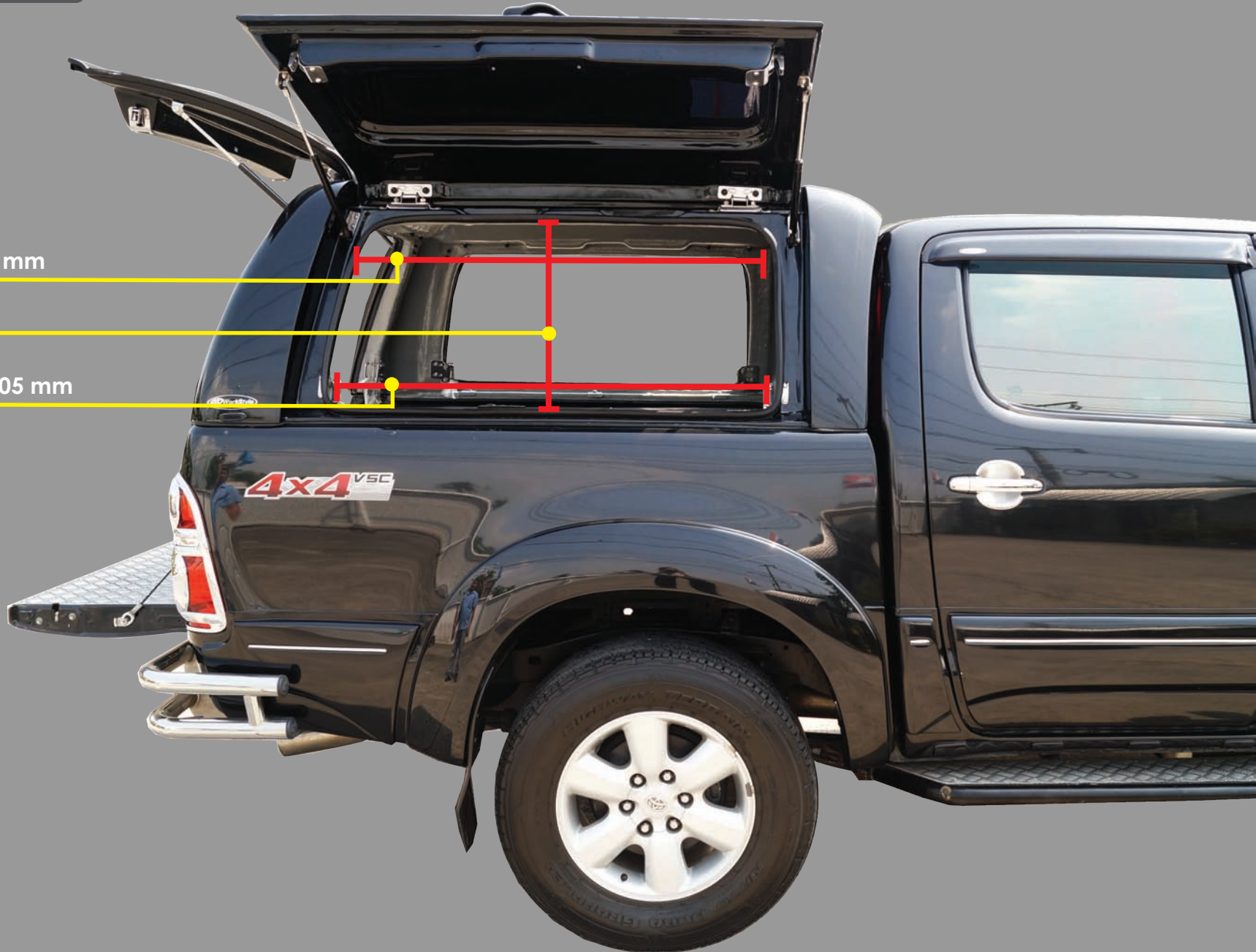

Minimum Width : 980 mm

Height : 475 mm

Maximum Width : 1,005 mm

Toyota Hilux.MK.6-7-8 (Vigo) Dbl-Cab

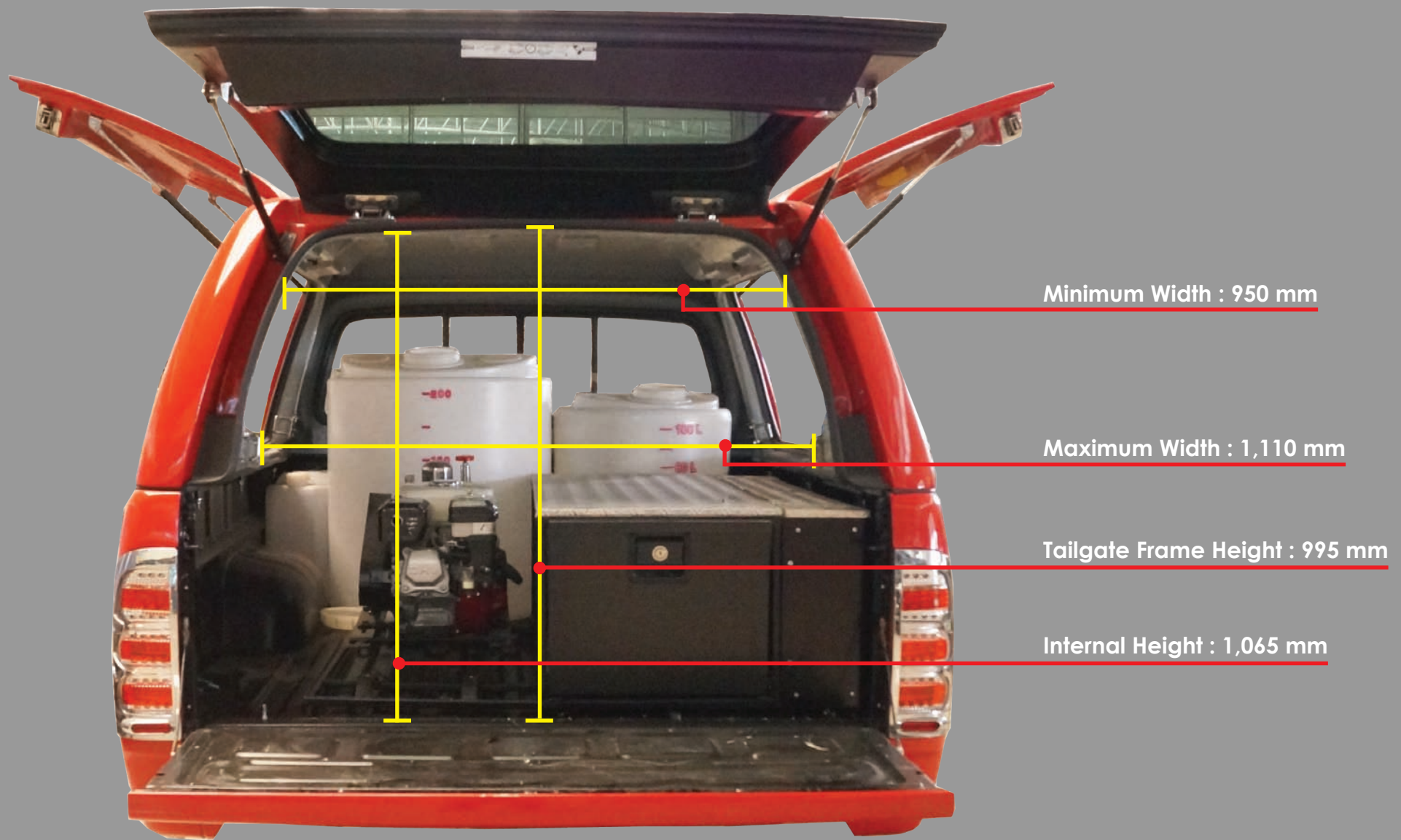

Toyota Hilux.MK.6-7-8 (Vigo) Extra-Cab

Minimum Width : 1,260 mm

Height : 485 mm

Maximum Width : 1,290 mm

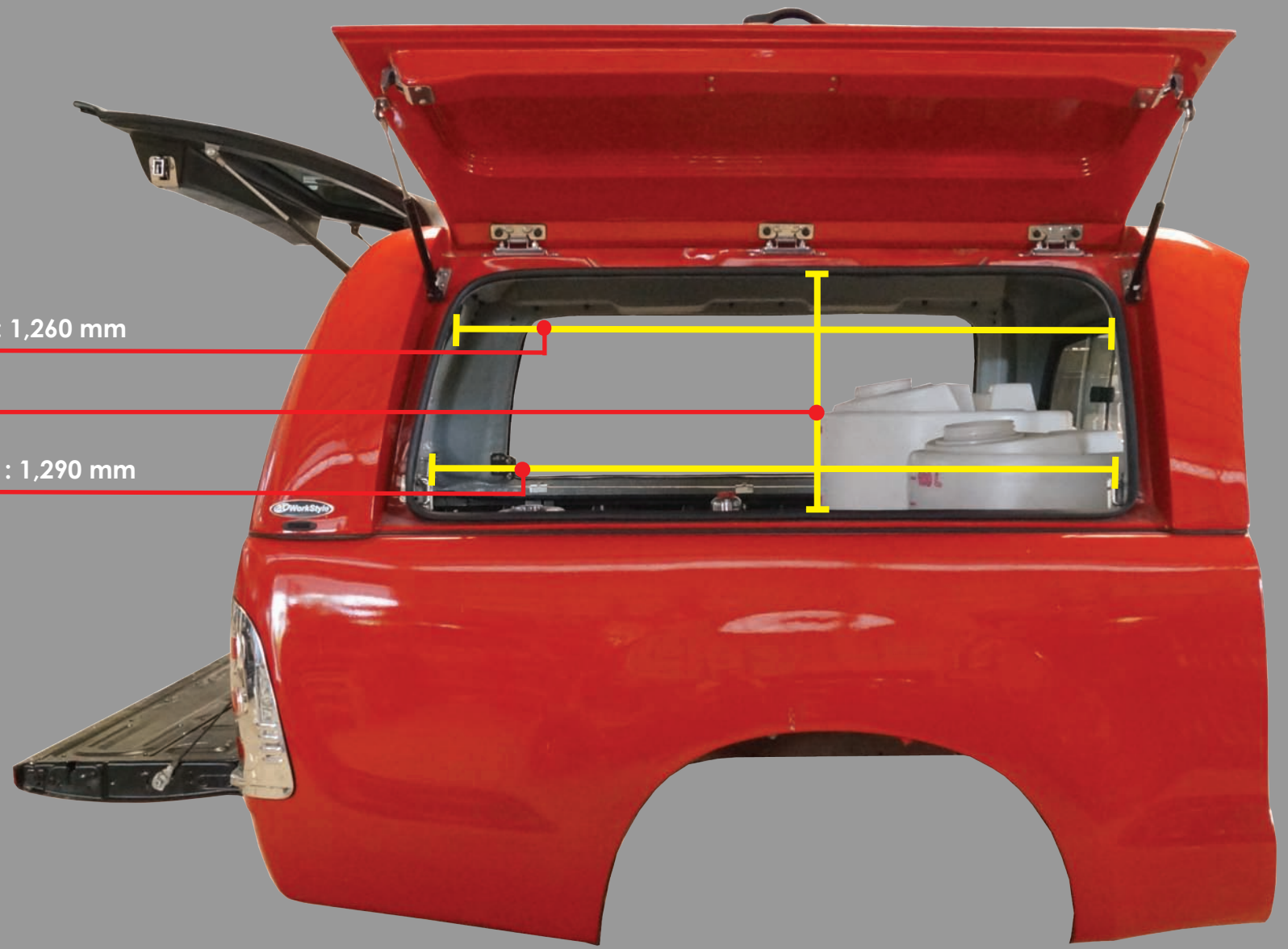

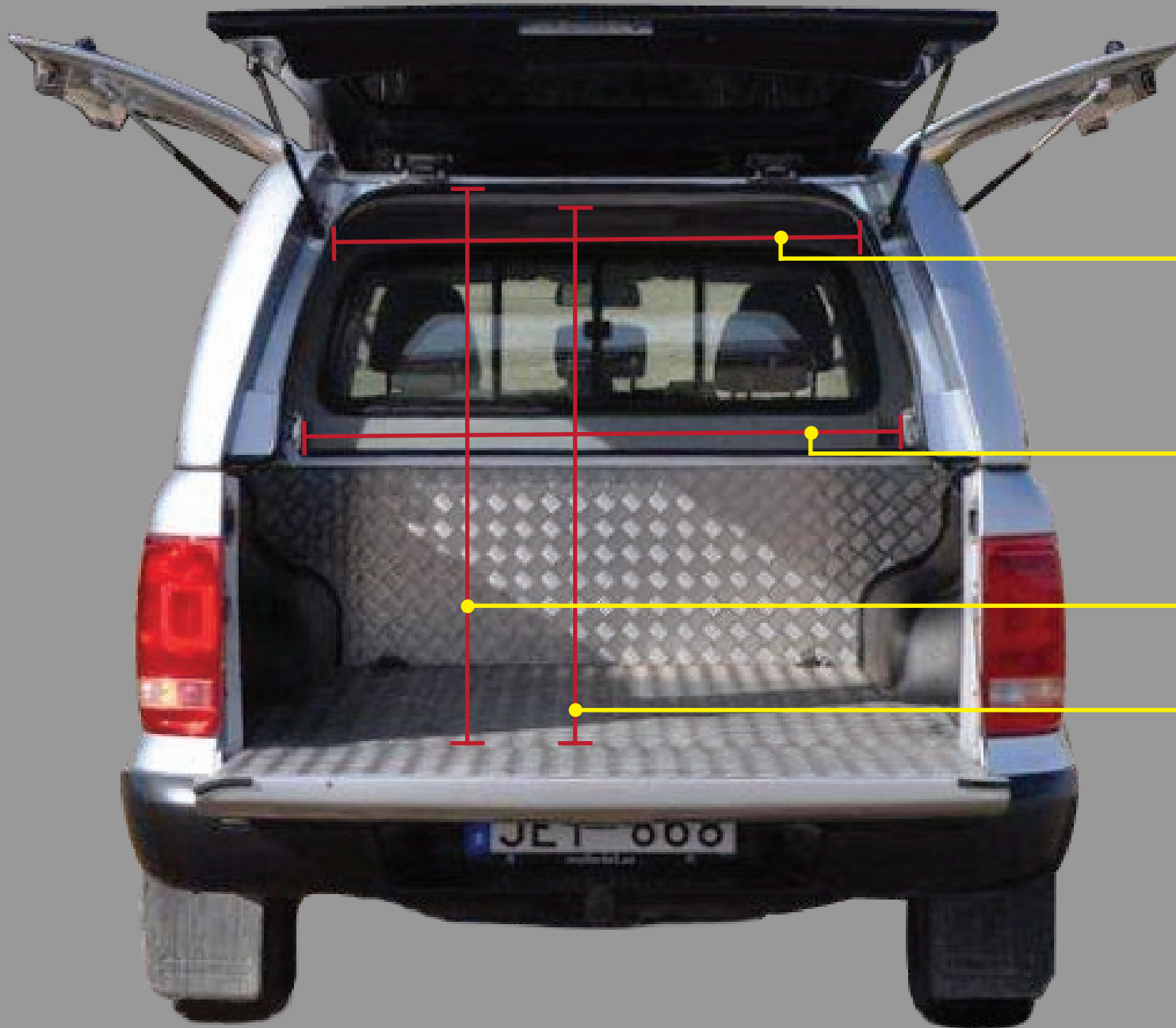

Minimum Width : 1,030 mm

Maximum Width : 1,130 mm

Tailgate Frame Height : 1,030 mm

Internal Height : 1,100 mm

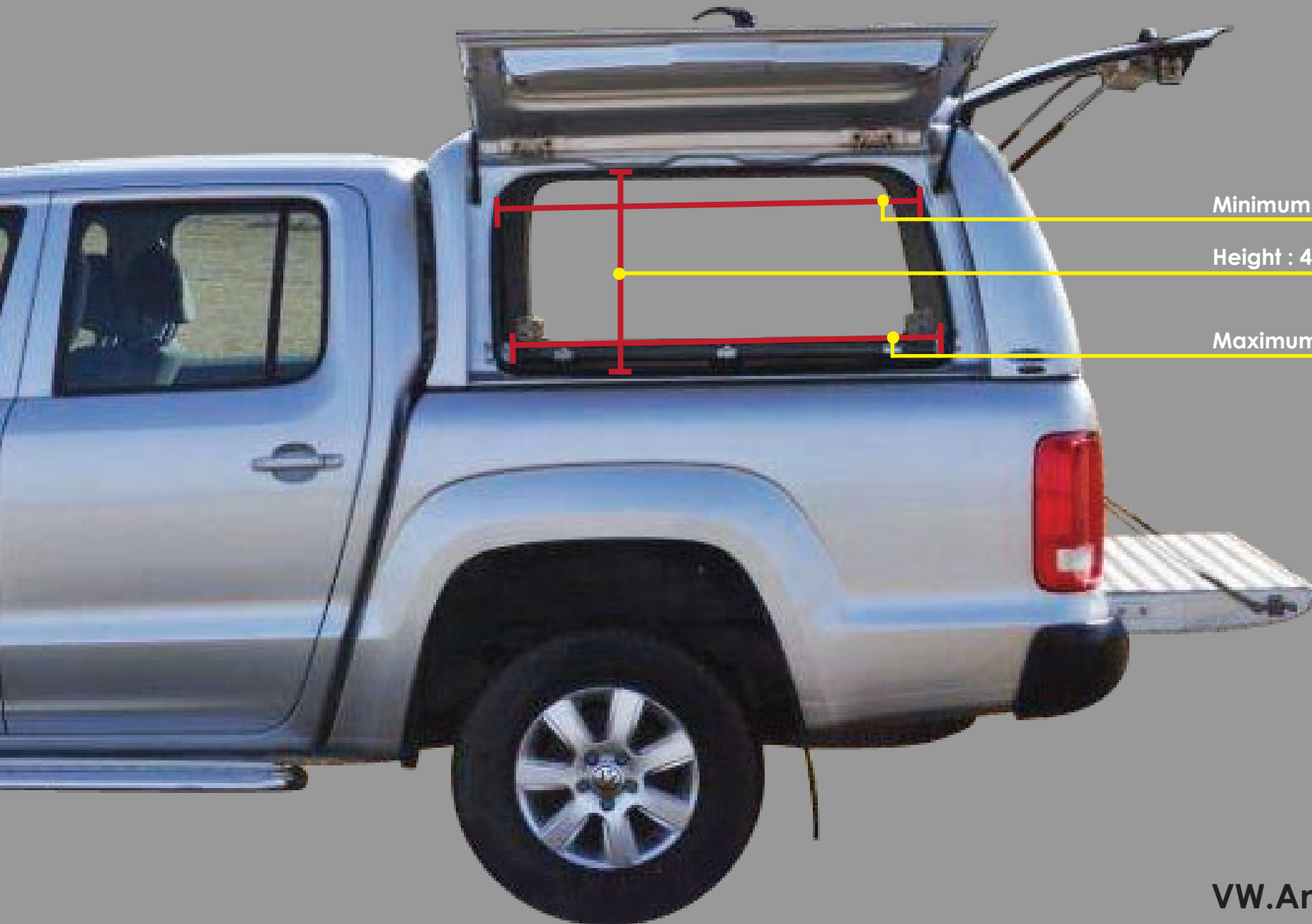

Minimum Width : 990 mm

Height : 470 mm

Maximum Width : 1,040 mm